

# Intelligent conveying equipment parts

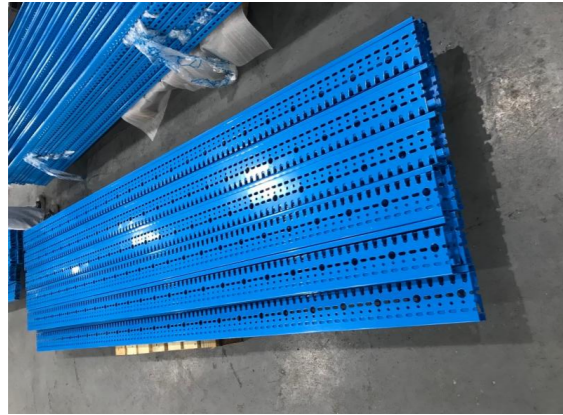

## Taper sleeve

specification	Effective length (mm)	microcephaly (mm)	The largest part (mm)
Half section	50	53.1	55.9
1	100	56	62.8
2	100	62.9	69.1
3	100	69.2	74.4
4	100	74.5	80.8
5	100	81	87.1
6	100	87.3	93.7
7	100	93.9	100
8	100	100.2	106.3
9	100	106.5	112.6
10	100	112.8	118.3
11	100	118.5	124.7

## Straight bushing



Serial number	specification
1	50-70*100mm
2	50-70*120mm
3	50-80*80mm
4	60-80*100mm
5	60-80*120mm
6	76-96*160mm
7	50-60*100mm一体式
8	60-70*100mm一体式

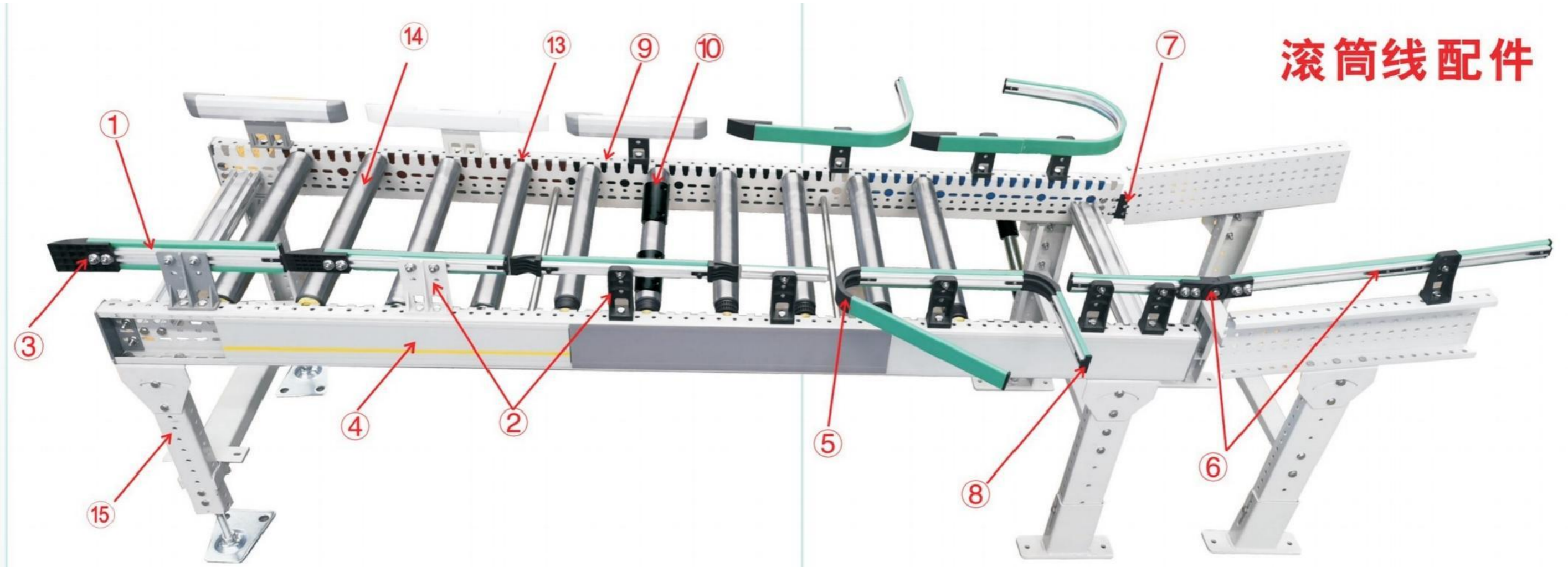

## 滚筒线配件

Serial number	name	specification	unit	remark
1	护栏	大C、中C、小C、小C-20、纯铝、纯塑	支	下料或3米 (可定制食品级)
2	支架	黑色护栏支架(100*40*30) 灰色护栏支架(100*80*30)	个	
3	标准导向头	大C、中C、小C、纯铝、纯塑、小C20	个	
4	机架防尘板	双色(灰、黄色)、灰色、深灰、红色、蓝色、黑色 (机架开口86MM)*3M	支	定制颜色
5	护栏弯头	30° 中C、90° 中C、可定制任意角度护栏	个	
6	连接件	护栏连接件、中C爬坡连接件、C型钢连接件	个	
7	封盖	C型钢端盖	个	
8	端盖	大C端盖、中C端盖	个	

Serial number	name	规格/specification	unit	remark
9	C型钢	40*120*17*3、 “35*115*14.5*2.8(机架开口86MM)	支	长度可定制
10	直套	50-70*100mm、50-70*120mm、50-80*80mm、 60-80*100mm、60-80*120mm、76-96*160mm、 50-60*100mm一体式、60-70*100mm一体式	个	
11	多楔带	2PJ、3PJ	个	
12	辊筒配件	多楔带轮、塑座	套	普通轴承
13	卡扣	S11六角轴辊筒卡扣、防夹手卡扣	个	
14	辊筒	按图定制	支	
15	支腿	按图定制	个	

# Intelligent conveying equipment parts

## ① 护栏

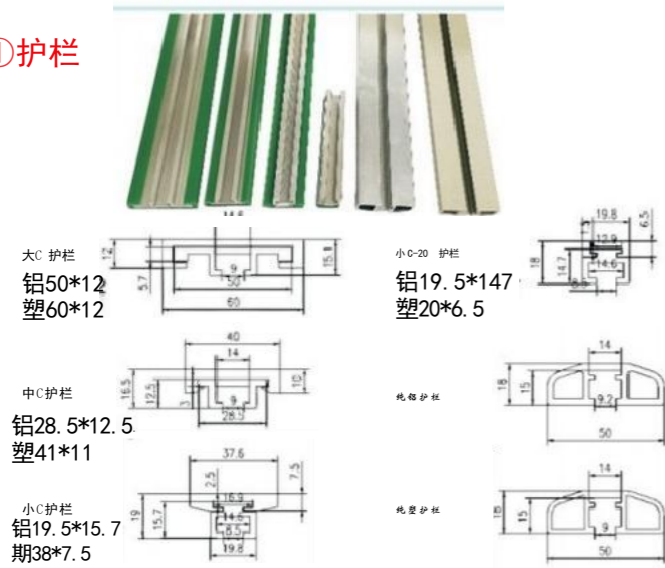

## ② 支架



## ⑧ 端盖

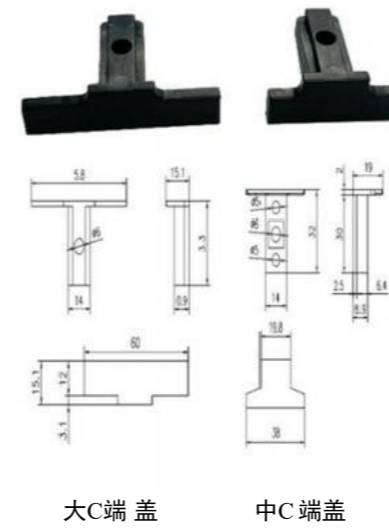

## ⑨ C型钢

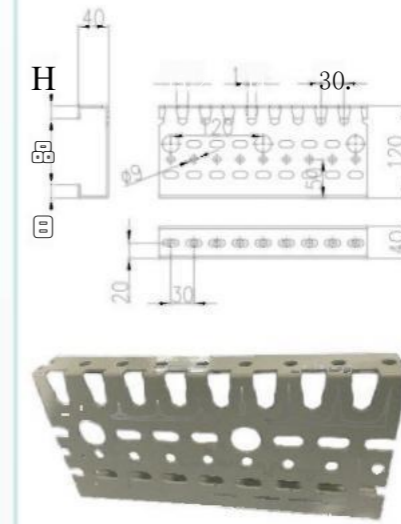

## ⑩ 直套

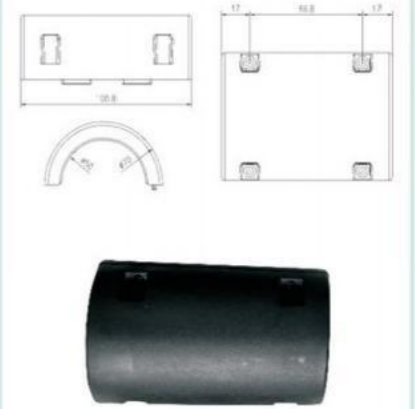

## ③ 导向头

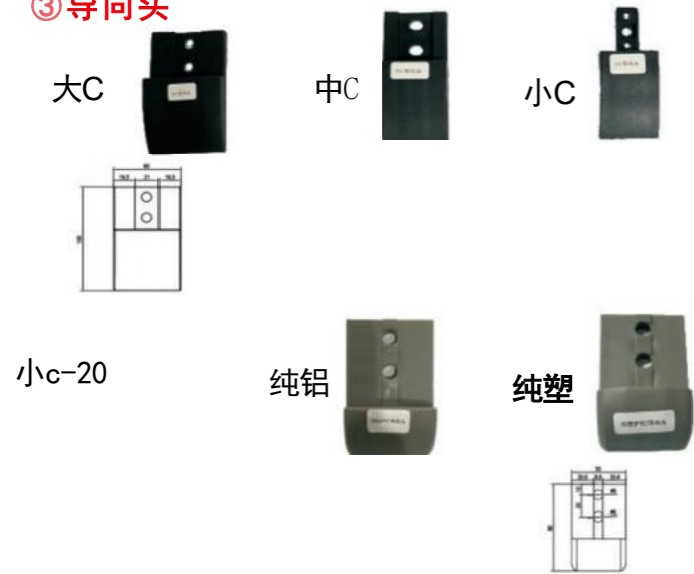

## ④ 机架防尘板

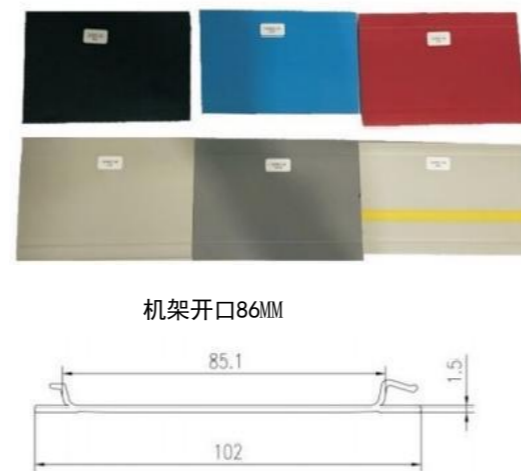

## 多楔带

	2pj
	3pj
中心距	型号
60	PJ256
75	PJ286
90	PJ314
100	PJ336
120	PJ376
125	PJ390
150	PJ435

## ⑬ 卡扣



## ⑮ 支腿

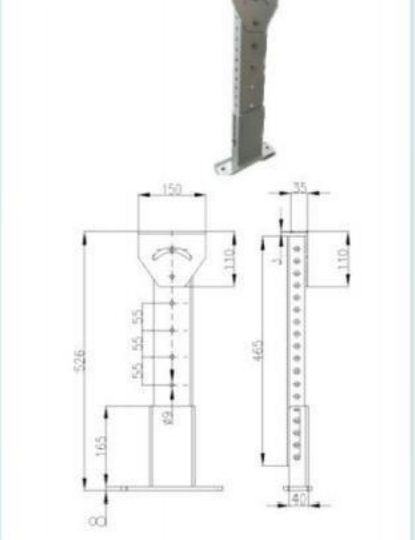

## ⑤ 护栏弯头



## ⑥ 连接件



## ⑦ 封盖



## 14 辊筒

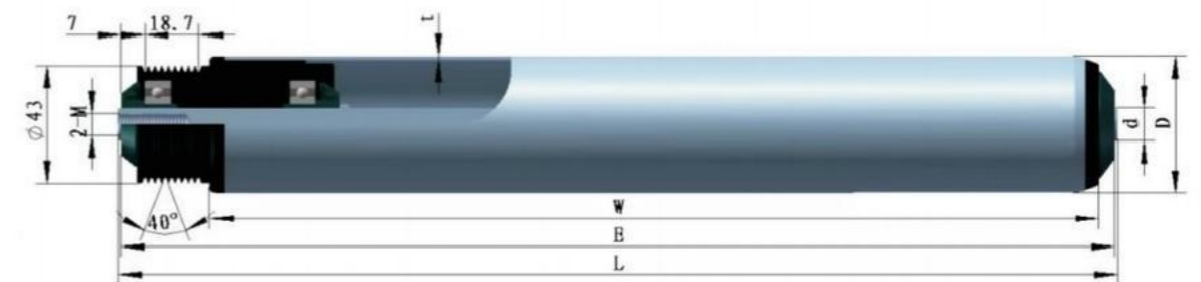

## Chain conveyor attachment

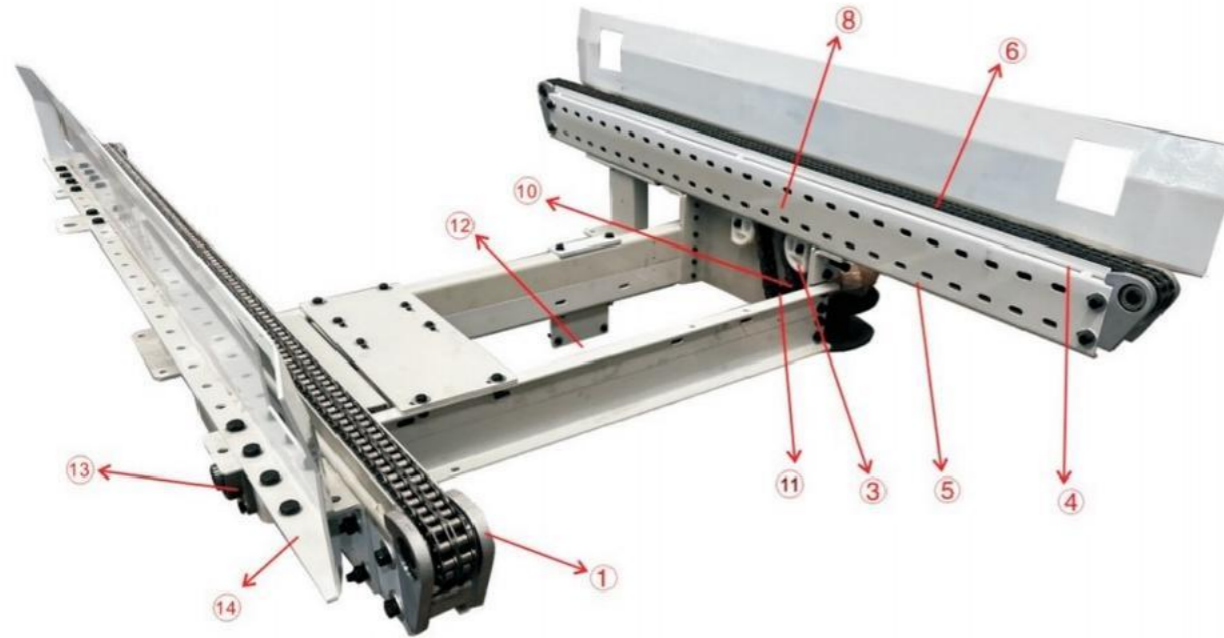

Serial number	name	specification	unit	quantity	remark
1	头尾轮	铝合金配C10B-2链条	只		哈尔滨6004
2	涨紧轮	铝合金	只	1	哈尔滨6004
3	涨紧轮	高分子	只	1	可带方螺母M16
4	托条	18米/条, 超高分子材质	米		白色
5	滑块套件	56*40*12, 镀锌/发黑+塑料套件	套	1	
6	链条	C10B-2/3.048米/条	条	1	
7	机架、导槽	120*71*14*无孔+卡槽焊接	米		
8	机架、导槽	120*71*14*有孔+卡槽焊接	米	1	
9	杯脚	M20鸭掌*8mm*150mm	只	1	可定做规格
10	驱动电机链轮	10B15齿双排(可定制)	只		发黑
11	驱动电机链轮轴上用	10B17齿双排(可定制)	只	1	发黑
12	驱动轴	按照客户要求	支		调质发黑带轴套
13	带座轴承座	UCFC206(可定制)	只		
14	钣金件	按图制作	批		
15	支腿	按图制作	批		

①头尾轮



②涨紧轮

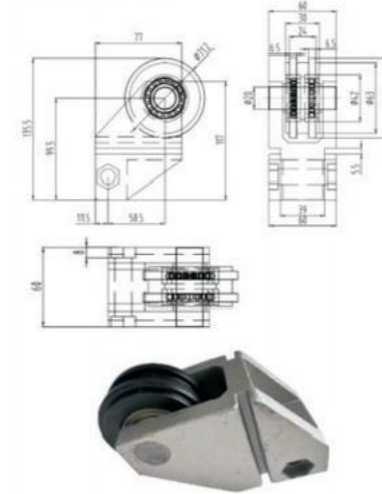

③涨紧轮

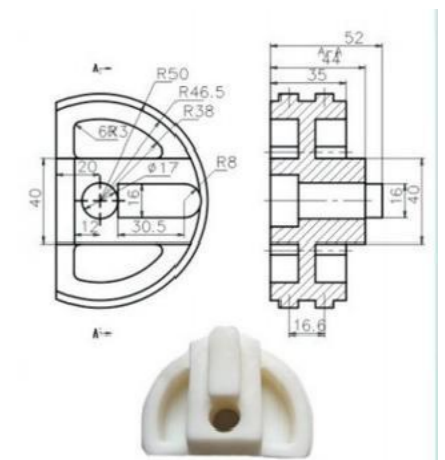

④托条

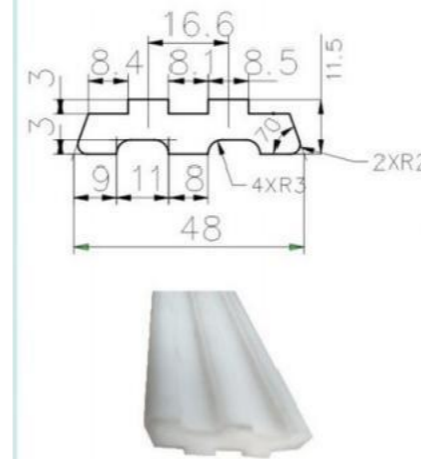

⑤滑块套件

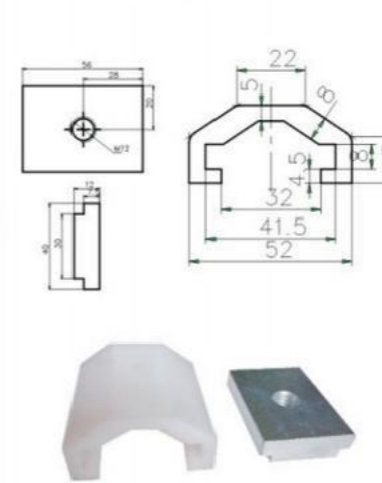

⑦机架、导槽

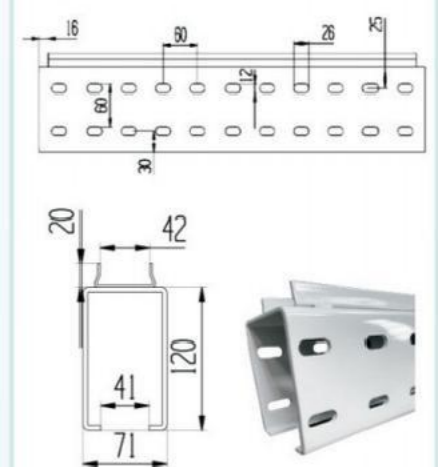

⑨杯脚

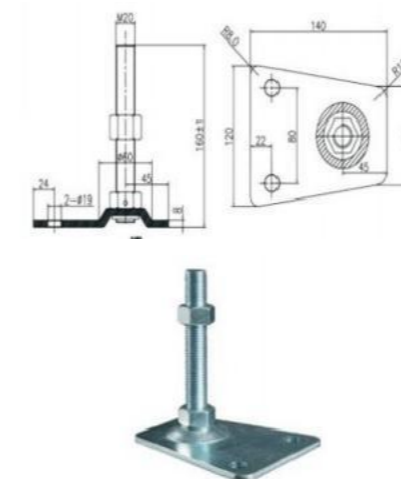

驱动电机链轮轴上用

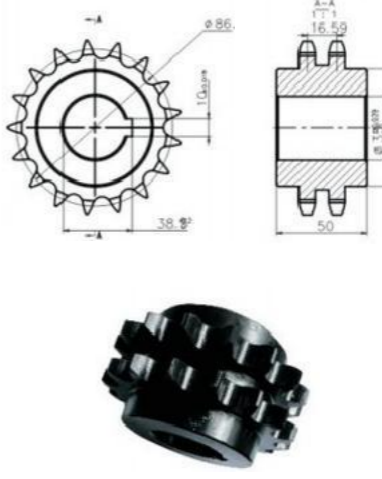

⑮支腿

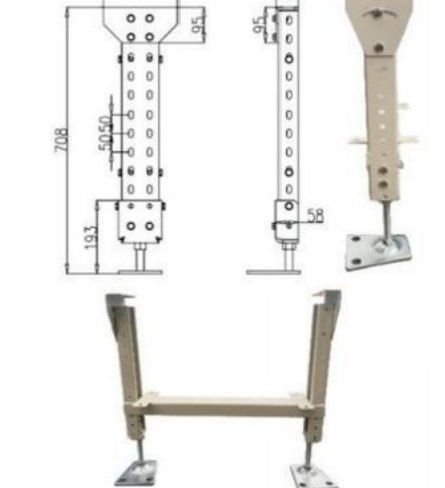

## 多楔带轮

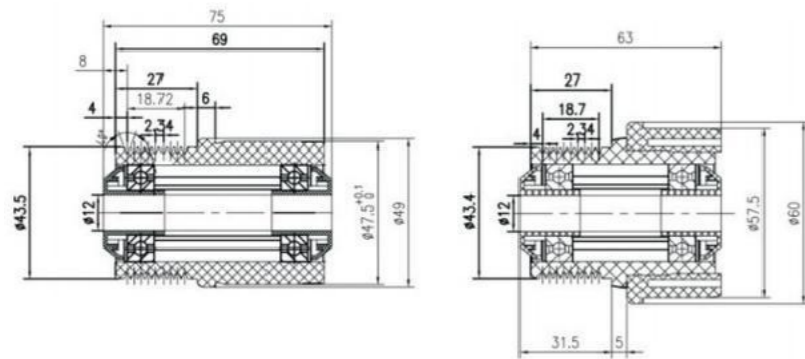

序号	规格	轴径
1	501.0	12轴、s11六角轴、15轴
2	501.2	12轴、s11六角轴、15轴
3	501.5	12轴、s11六角轴、15轴
4	601.5	12轴、s11六角轴、15轴
5	602.0	12轴、s11六角轴、15轴

## 塑钢链轮

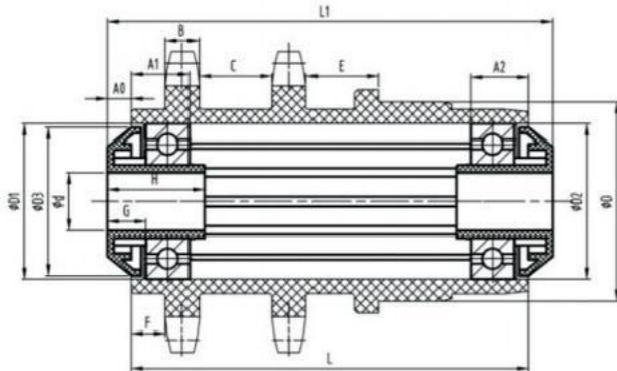

序号	规格	轴径
1	11T单链	12轴、S11六角轴
2	11T单链积放	12轴、S11六角轴
3	11T双链	12轴、S11六角轴
4	11T双链积放	12轴、S11六角轴
5	14T单链	12轴、s11六角轴、15轴
6	14T单链积放	12轴、s11六角轴、15轴
7	14T双链	12轴、s11六角轴、15轴
8	14T链积放	12轴、s11六角轴、15轴

## 不收口塑座

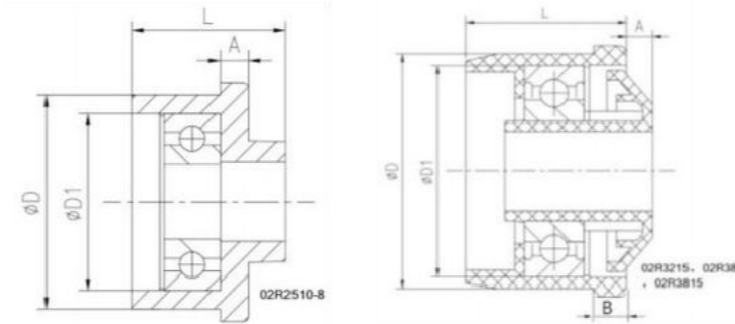

序号	规格	φD	A	B	轴径
	251.0-8	φ23.2	4mm		8轴
2	251.0-8凸台	φ23.2	4mm	4mm	8轴
3	321.0	φ30.2	5mm	4mm	8轴、10轴、12轴
4	321.2	φ29.8	5mm	4mm	8轴、10轴、12轴
5	321.5	φ29.2	5mm	4mm	8轴、10轴、12轴
6	381.0	φ36.2	5mm	5mm	8轴、10轴、12轴、s11六角轴、15轴
7	381.2	φ35.8	5mm	5mm	8轴、10轴、12轴、s11六角轴、15轴
8	381.5	φ35.2	5mm	5mm	8轴、10轴、12轴、s11六角轴、15轴
9	382.0	φ34.2	5mm	5mm	8轴、10轴、12轴、s11六角轴、15轴
10	383.0	φ32.2	5mm	5mm	8轴、10轴、12轴、s11六角轴、15轴
11	421.5	φ39.3	5mm	5mm	8轴、10轴、12轴、s11六角轴、15轴
12	501.0	φ48.3	5mm	5mm	8轴、10轴、12轴、s11六角轴、15轴
13	501.2	φ47.9	5mm	5mm	8轴、10轴、12轴、s11六角轴、15轴
14	501.5	φ47.3	5mm	5mm	8轴、10轴、12轴、s11六角轴、15轴
15	502.0	φ46.3	5mm	5mm	8轴、10轴、12轴、s11六角轴、15轴
16	502.5	φ45.3	5mm	5mm	8轴、10轴、12轴、s11六角轴、15轴
17	503.0	φ44.3	5mm	5mm	8轴、10轴、12轴、s11六角轴、15轴
18	571.5	φ54.3	5mm	5mm	8轴、10轴、12轴、s11六角轴、15轴
19	572.0	φ53.3	5mm	5mm	8轴、10轴、12轴、s11六角轴、15轴
20	601.2	φ57.9	5mm	5mm	8轴、10轴、12轴、s11六角轴、15轴
21	601.5	φ57.3	5mm	5mm	8轴、10轴、12轴、s11六角轴、15轴
22	602.0	φ56.3	5mm	5mm	8轴、10轴、12轴、s11六角轴、15轴
23	602.5	φ55.3	5mm	5mm	8轴、10轴、12轴、s11六角轴、15轴
24	603.0	φ54.3	5mm	5mm	8轴、10轴、12轴、s11六角轴、15轴
25	761.5	φ73.3	5mm	5mm	15轴、20轴
26	762.0	φ72.3	5mm	5mm	15轴、20轴
27	763.0	φ70.3	5mm	5mm	11轴、20轴

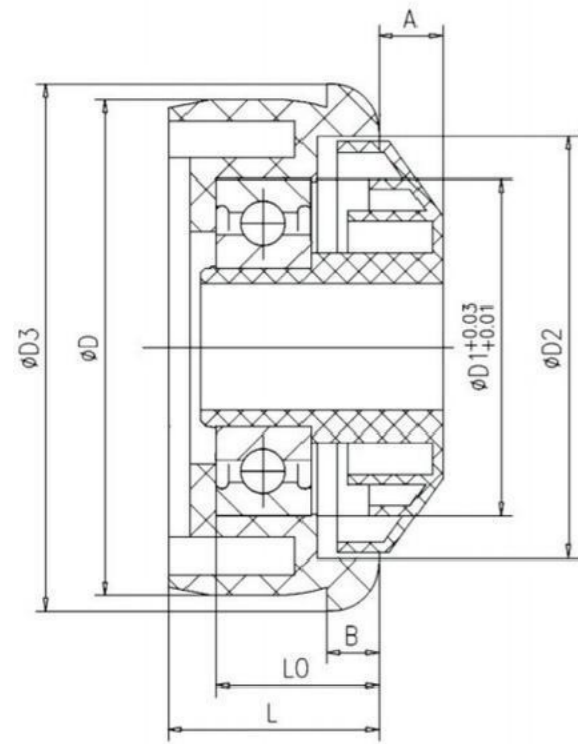

## 收口塑座



序号	规格	$\phi D$	A	B	轴径
1	381.2	$\phi 35.9$	5mm	5mm	12轴、s11六角轴、15轴
2	381.5	$\phi 35.3$	5mm	5mm	12轴、s11六角轴、15轴
3	501.2	①47.9	5mm	5mm	12轴、s11六角轴、15轴
4	501.5	①47.3	5mm	5mm	12轴、s11六角轴、15轴
5	502.0	$\phi 46.3$	5mm	5mm	12轴、s11六角轴、15轴
6	601.2	$\phi 57.9$	5mm	5mm	12轴、s11六角轴、15轴
7	601.5	$\phi 57.3$	5mm	5mm	12轴、s11六角轴、15轴
8	602.0	①56.3	5mm	5mm	12轴、s11六角轴、15轴
9	761.5	$\phi 73.3$	5mm	5mm	15轴、20轴
10	762.0	$\phi 72.3$	5mm	5mm	15轴、20轴

## 福来轮



### GA-01 系列



型号	材质	d	D	W	W1	静载(kg)	动载(kg)	自重(g)
GA-01-8	ABS	$\phi 8.1$	$\phi 48.5$	16	18	40	60	35
GA-01A-8	ABS	$\phi 8.1$	$\phi 38$	14.3	18	35	50	26
GA-01B-8	ABS	$\phi 8.1$	$\phi 30$	24.1	28.5	20	25	25.5

### GA-02 系列

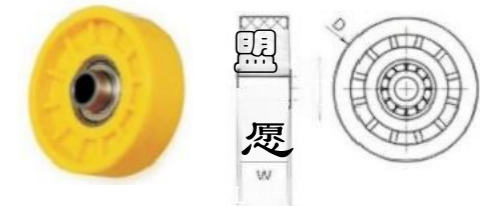

型号	材质	d	D	W	W1	静载(kg)	动载(kg)	自重(g)
GA-02-8	ABS	$\phi 8.1$	$\phi 48.5$	16	18	40	60	30

### GB系列



型号	材质	d	D	W	W1	静载(kg)	动载(kg)	自重(g)
GB-01-6	钢制/镀锌	$\phi 6.1$	$\phi 38$	13.1	20.4	8	10	56
GB-02A-8	钢制/镀锌	$\phi 8.1$	$\phi 48$	15.3	18	8	15	66
GB-02B-6	钢制/镀锌	$\phi 6.1$	$\phi 48$	15.3	19.9	35	45	105

## 挡圈

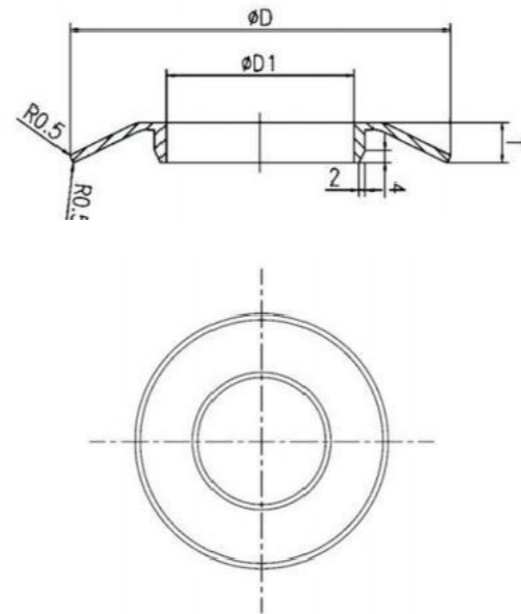
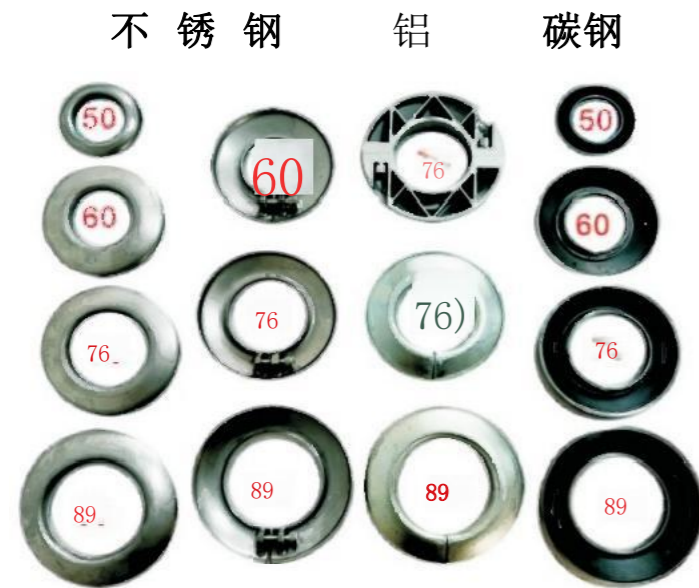

序号	型号	材质	D	D1	T
1	50挡圈	碳钢/不锈钢	80	50	10
2	60挡圈	碳钢/不锈钢	120	60	12
3	76挡圈	碳钢/不锈钢	135	76	11.5
4	89挡圈	碳钢/不锈钢	150	89	15.8
5	60活动挡圈	碳钢/不锈钢	120	60	13.4
6	76活动挡圈	碳钢/不锈钢/铝	135	76	13
7	89活动挡圈	碳钢/不锈钢	150	89	17

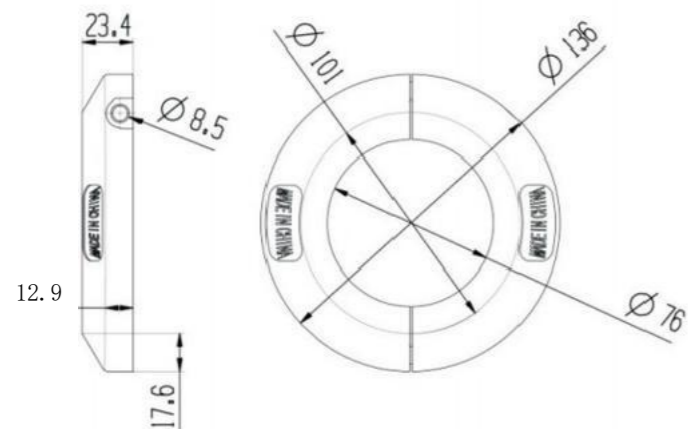

## 铝挡圈



## 杯脚

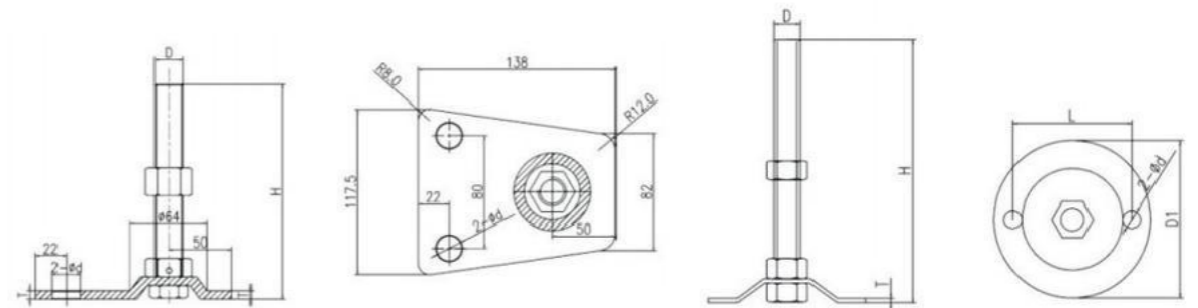
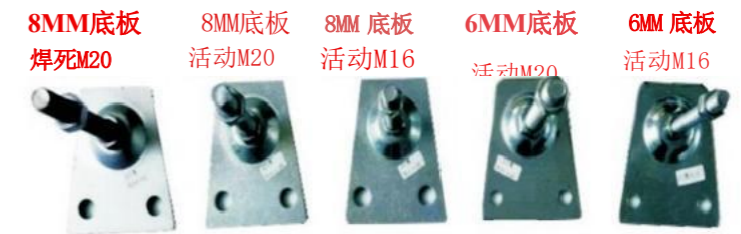

序号	型号	材质	H	T	D	d	D1
1	鸭掌杯脚8MM底板焊死M20	碳钢/不锈钢	150	8	20	19	/
2	鸭掌杯脚8MM底板活动M20	碳钢/不锈钢	150	8	20	19	/
3	鸭掌杯脚8MM底板活动M16	碳钢/不锈钢	150	8	16	19	/
4	鸭掌杯脚6MM底板活动M20	碳钢/不锈钢	150	6	20	16	/
5	鸭掌杯脚6MM底板活动M16	碳钢/不锈钢	150	6	16	16	/
6	圆形杯脚5MM底板活动M16	碳钢/不锈钢	150	5	16	12	120
7	圆形杯脚5MM底板活动M14	碳钢/不锈钢	150	5	14	12	120
8	圆形杯脚3MM底板活动M14	碳钢/不锈钢	140	3	14	11	95
9	圆形带勾杯脚3MM底板活动M14	碳钢/不锈钢	120	3	14	10	80
10	圆形杯脚3MM底板活动M12	碳钢/不锈钢	120	3	12	/	80

## PVC软胶套



序号	名称	规格
1	50软胶套	φ 50*2mm
2	60软胶套	φ 60*2mm

## PVC管

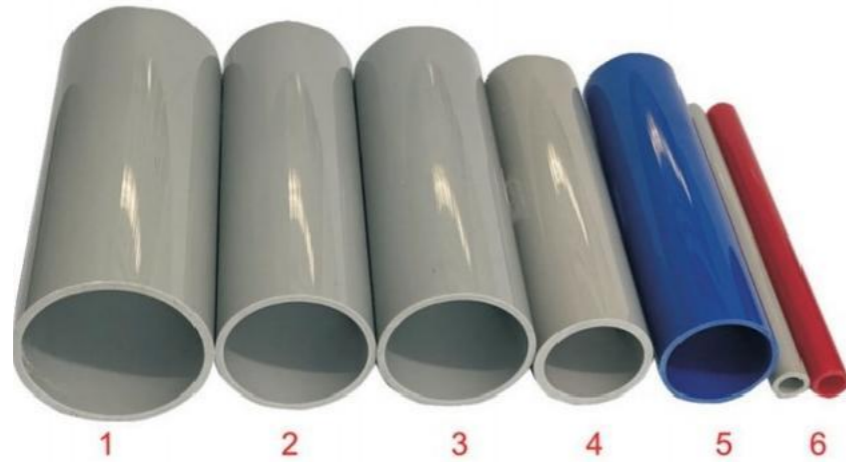

序号	名称	外径	厚度
1	PVC管	60	3mm
2	PVC管	50	3mm
3	PVC管	50	2.5mm
4	PVC管	38	3mm
5	PVC管	38	2mm
6	PVC管	12	1.6mm

## 防尘盖

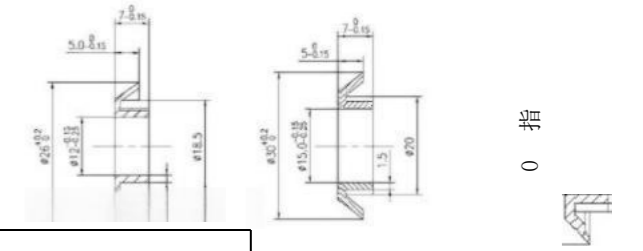

序号	规格	尺寸	用途
1	12轴防尘盖	φ 12* φ 25.7	搭配6001轴承使用
2	15轴防尘盖	φ 15* φ 30	搭配6002轴承使用
3	20轴防尘盖	φ 20* φ 40	搭配6004轴承使用
4	12轴大防尘盖	φ 12* φ 30	搭配6201轴承使用
5	15轴大防尘盖	φ 15* φ 33	搭配6202轴承使用
6	20轴大防尘盖	φ 20* φ 45	搭配6204轴承使用

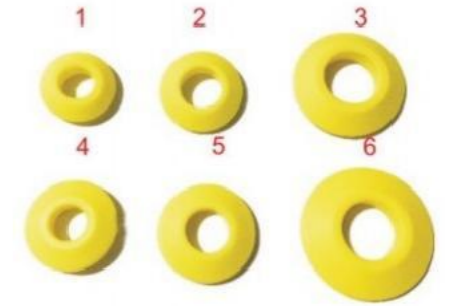

## 螺钉塞

序号	规格	用途
1	M6螺钉塞	防止滚筒使用前轴链轮、轴承、轴套、通轴等掉出，使用滚筒时拔出即可。
2	M8螺钉塞	
3	M10螺钉塞	
4	M12螺钉塞	



## 轴套隔套

序号	规格	用途
1	12轴轴套L15.5* φ 15.8	保护内圈，防止轴承内环的磨损，并同时起到定位和支撑作用
2	15轴轴套L15.3* φ 20.5	
3	12轴隔套L25* φ 26	分隔两个轴承，防止彼此接触和摩擦，从而避免损坏和磨损，同时保证轴的正常运转。
4	15轴隔套L15.1* φ 26	





## 其他轮子



序号	品名	规格	轴径
1	一体式同步带轮	T5-26齿	12轴、S11六角轴、15轴
2	同步带轮	T5-26齿	12轴、S11六角轴、15轴
3	花键套	501.2、501.5、502.0、 601.5、602.0、602.5、 603.0	
4	0带轮501.2-12	501.2、501.5	12轴、S11六角轴、15轴

序号	品名	规格	用途
1	多楔带轮过渡轮组件	9沟8槽	伸缩机 同步带线
2	同步带轮过渡轮	T5-26齿	
3	50-0带轮过渡轮	双槽	
4	同步带轮	T10-18齿双排	移载机
5	横斜撑垫圈-直径52	$\phi 52 * \phi 11 * L36$	
6	横斜撑垫圈-直径42	$\phi 42 * \phi 11 * L25$	
7	皮带导向轮	白色绿色 \ $\phi 30 * 11 * 2 * M5$ 螺杆 * L50	转弯皮带机
8	导向轮	$\phi 30 * L21$	皮带机
9	张紧轮	D49.2 * d45.5 * L24.5 配6001	
10	张紧轮	D36 * d30 * L24.5 配6901 * 2	

Mecanum wheel series

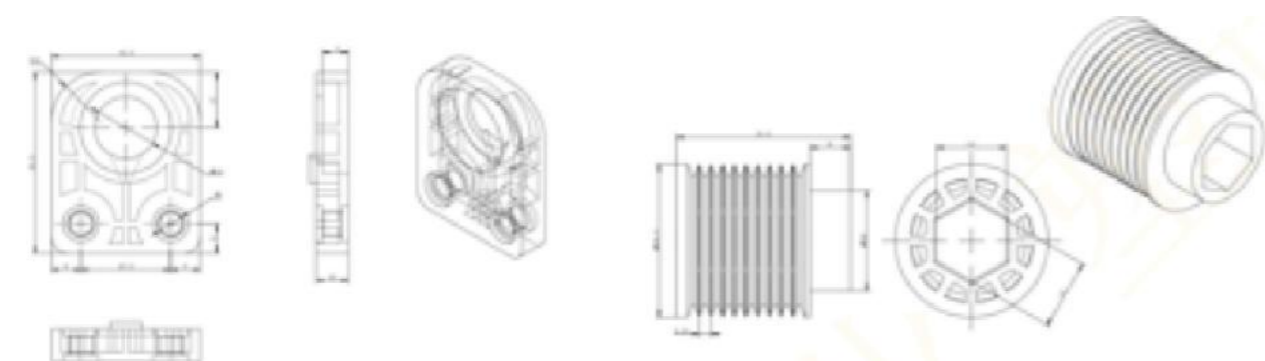

轴承座

六角多楔带轮



麦克纳姆轮 (右)

麦克纳姆轮 (左)

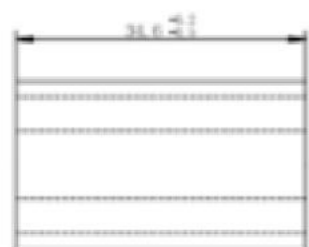

隔套 (标准长度1M)

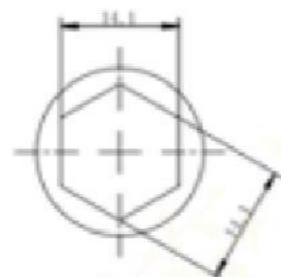

全方位移动的全向轮

序号	1	2	3	4	5	6
类型	50直轮	50斜轮	轴承座	六角套管	六角多楔带	六角支撑轴套

With pearl skate wheel bearing

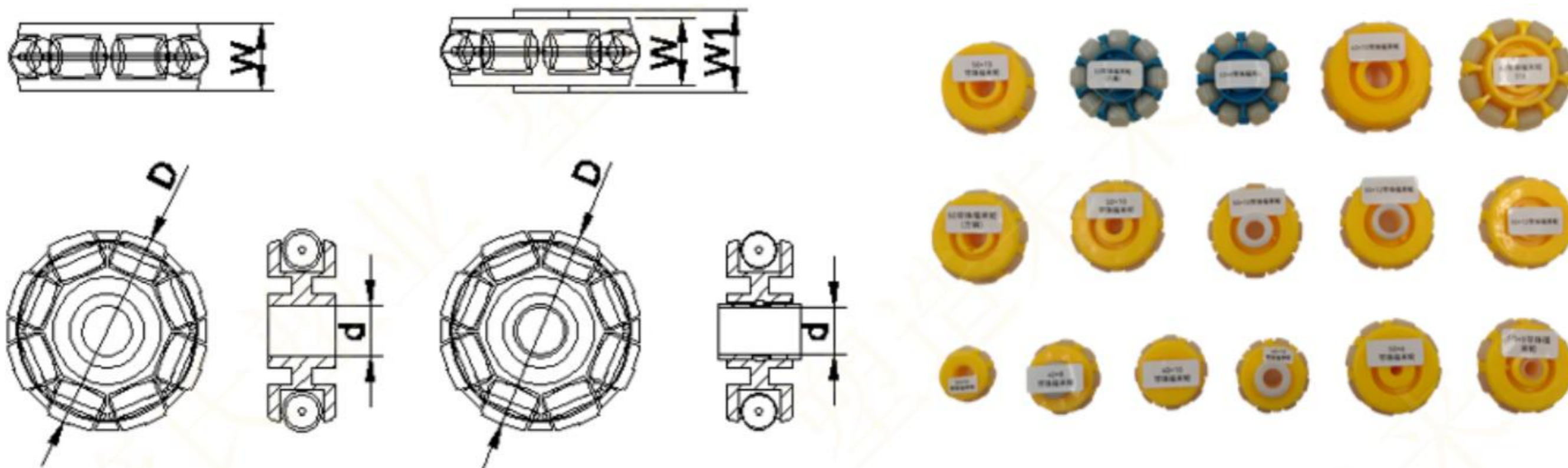

型号	1	2	3	4	5	6	7	8	9	10	11	12	13	14	15
d(φ)	8.3	12.3	12.3	10.3	13.1	10.3	13	6.2	8.3	内六	10.3	8.3	10.3	10.3	内六
D(φ)	50.5	50.5	50.5	50.8	50.5	50.8	51.3	50.9	53	53	40	40	40	30	60
W(mm)	16.5	16.5	16.5	16.3	16.5	16.5	16.3	16.5	21.3	21.3	15	15	15	12	21
W1(mm)	20.5	20.5	27	16.3	16.5	27	16.3	16.5	21.3	21.3	15	25	25	12	21
自重(g)	29	27	29	27	26	30	25	26	28	28	10	15	15	7	45

静载8kg, 动载10kg

Skate wheel bearing

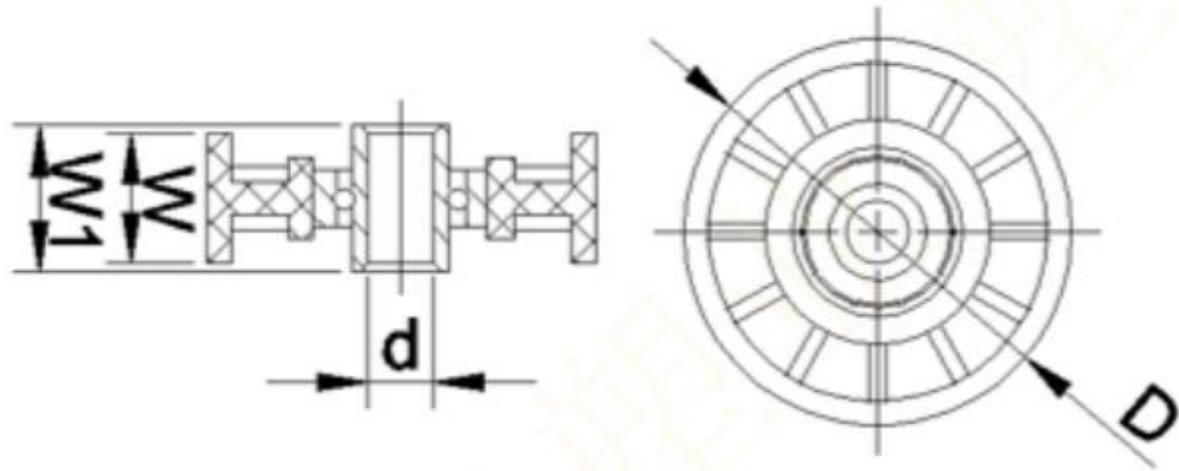

型号	1	2	3	4	5	6	7	8	9	10	11	12	13	14
d(φ)	5	8	8	8	8	8	8	8	8	8	8	8	12	8
D(φ)	22	26	30	38	38	38	48	48	48	48	48	48	48	70
W(mm)	20	8	24	14	14	24.5	16	16	16	16	16	16	16	16
W1(mm)	25.5	18	28.5	18	28.5	28.5	18	18	7	28.5	50	无	8	28.5
规格	标准	标准	加长 加宽	标准	加长	加长 加宽	实心	花件	花件	加长	特长	无轴 承	6001- 12轴	标准

Universal wheel series

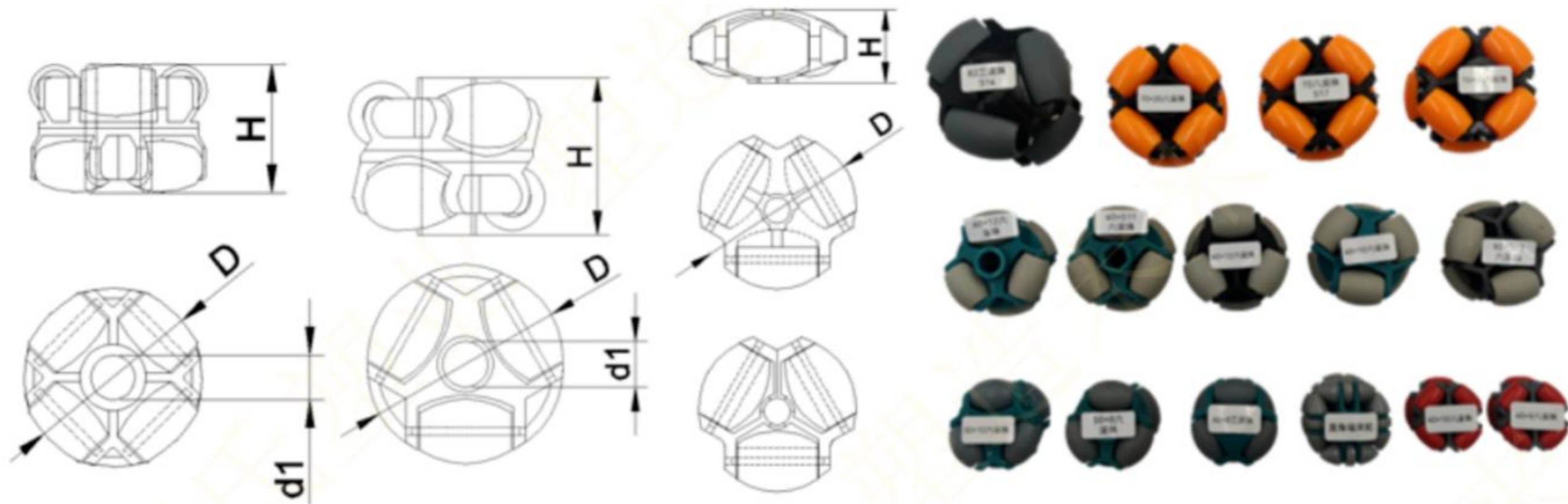

D(φ)	40	40	50	50	52	60	60	60	60	60	60
珠数	8	8	6	6	6	6	6标准	6标准	6加高	6加高	6加高
d(φ)	8	10	8	10	12	15	12	S11	10	12	S11
H(mm)	29	29	40	40	40	40	40	40	44	44	44
D(φ)	60	70	70	70	70	70	48	82	82	82	82
珠数	6加高	8	8	8	8	8	6双层	6双层	6双层	6双层	6双层
d(φ)	S12	15	20	S14	S16	S17	8	12	S11	S13	S14
H(mm)	44	46	46	46	46	46	40	65	65	65	65

transport

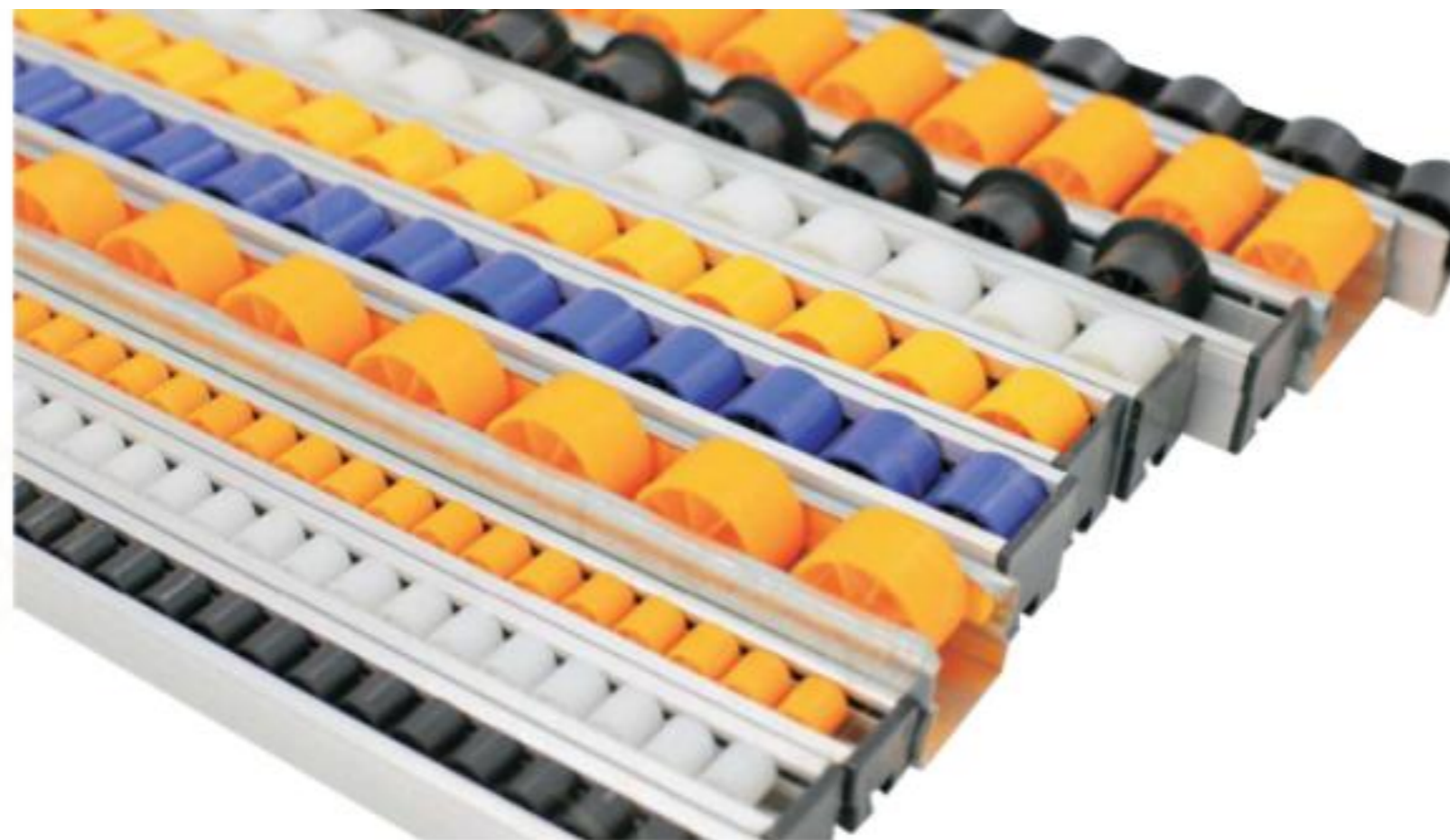

序号	1	2	3	4	5	6	7	8	9
规格	R13	R28	R28D	R28E	R24	R33	R38	28钣金	32钣金

序号	1	2	3	4	5
规格	φ30福来轮	φ38福来轮	φ38钢制福来轮	φ48福来轮	φ48钢制福来轮

Chain plate series

7705型  
平板链网

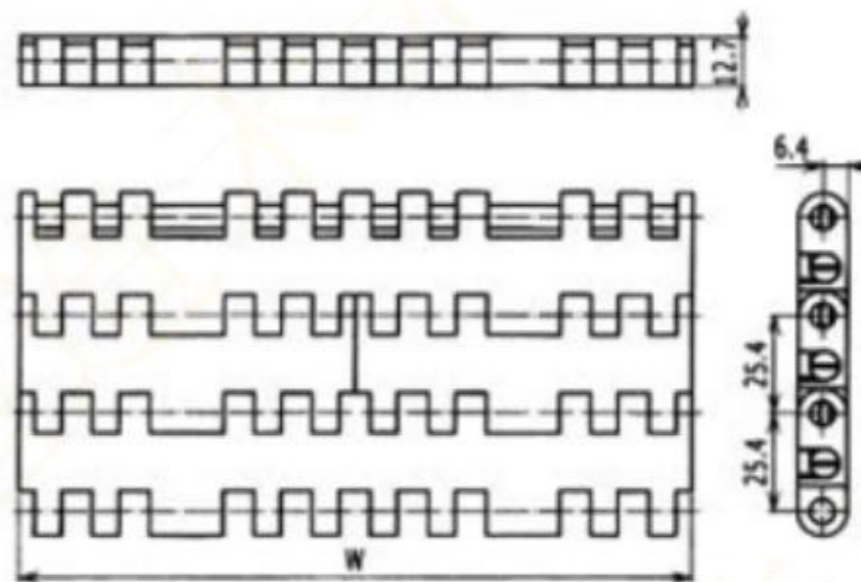

880导  
侧弯链

